

SIG 41

APPARATUS COMPONENT PRODUCTS

07,23

SCBA COMPARTMENTS

11,26

FOLDING STEPS

09,25

FUEL DOORS

13

GRAB RAILS,
EXPANDABLE STEPS

15

OPERATOR PANEL ASSEMBLIES
AND ELECTRO MECHANICAL
SUB ASSEMBLIES

19,26

VALVE CONTROLS

17

LOGOS, BRAND IDENTIFICATION,
PLAQUES AND STAINLESS STEEL TAGS



4

WE BUILD OUR IMAGE ON ENHANCING YOURS

As with all great masterpieces, the finishing touch is the signature of its creator. It allows the owner to know they possess a product "original" of unique quality and design. Our passion is to afford the look you desire and the function you require. To achieve this, we offer a myriad of materials, decorative finishes, and forming processes to meet even the strictest specifications. Blending creative design with disciplined engineering, Signature 4's image enhancing solutions are as unique as your product. We invite you to experience the change as we build our image by enhancing yours.

SIGNATURE 4 IS A DESIGN, ENGINEERING AND FINISH COMPANY.

WE ARE A COMPLEX AND DIVERSE SOLUTIONS PROVIDER

TEAMS : Our departments constantly evolve, morph and adapt as new opportunities arise.

Executive + Management	Design	Information Technology
Production	Marketing	Safety + Quality
Assembly	Customer Service	Sales
Engineering	Financing	Shipping + Receiving

CAPABILITIES + EQUIPMENT : From start to finish, our processes allow us to assist during any stage of the journey.

Engineering Services	Stamping	Welding
Product Development	Overmolding	Polishing
Branding	Routing	Vacuum Forming
Conceptual Rendering	Waterjet	Color Match Paint
Marketing Support	Sandblast Etch	PCB/SMT
Trade Show Support	Laser Etch	Injection Molding
Video Production	Hi-Resolution Printing	Liquid Printing
Video Graphics	Large Format Printing	Assemblies
Web + App Design	Diecast	Harness + Electro-Mechanical Assemblies
Digital Interfaces	Thermal Forming	Wire/Molding Solutions
3D Printing + Fabrication	Powder Coating	Fabrication
Screen Printing	CNC	Installation



SCBA COMPARTMENTS

FEATURES

All 304 stainless steel hardware construction

One-piece drop in assembly for quick installation

Non-abrasive poly compartment surfaces for cylinder protection

Unmatched in industry for speed of installation and suitability of multiple apparatus

Excellent for RETRO-FIT installations - body cut out and mounting template provided

Positive latching devices

Door and latch gaskets provided for added corrosion resistance

Right and left side configurations available with straight or 5 degree angled tubes

1-2-3-4 bottle configurations

Customs available upon request

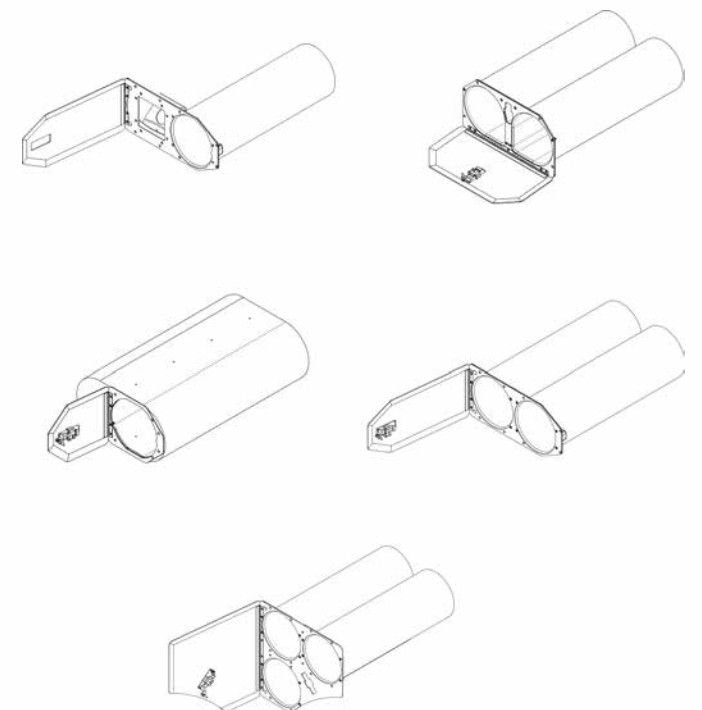

FUEL DOORS

FEATURES

All 304 stainless steel hardware construction with poly enclosure for superior corrosion resistance

Quick installation with minimum tools required

Positive or magnetic door latch

Rear enclosure available in stainless steel

Mounting template provided

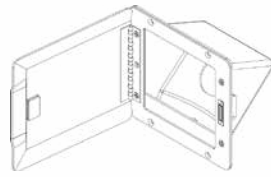

FOLDING STEPS

FEATURES

- Integrated grab handle, front or side
- Most aggressive stepping surface in industry
- Die cast zinc construction with SC1 chrome plated finish
- Quick installation, 4 bolt mounting template provided

LIGHTING

- All stepping surfaces are lit as a standard and NFPA 1901 compliant wherever installed
- Dual level LED lighting for surfaces below the step
- All LED's are mounted in a recessed pocket or protective housing

TESTING

- Static load test meets and exceeds NFPA 1901 compliance
- Passed up to 1000 lb load without deformation or failure
- Cycle test to 10,000 completed and passed for unmatched industry life and durability
- Slip resistance testing; NFPA 1901 compliant, automotive for apparatus section 15.7.3-ASTM F 1677-96 slip resistance test method

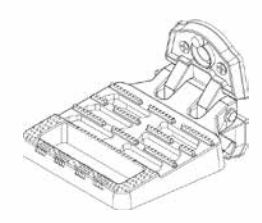

GRAB RAILS

FEATURES

All non-corrosive stainless steel construction

- NFPA 1901 Compliant
- Standard lengths ranging from 8.5" to 60"
- Customizable to desired length and shape

MATERIALS AND FINISHES

- Stainless Steel
- Aluminum
- Knurled / Brushed / Polished
- Powder Coating
- Anti-Microbial Coating

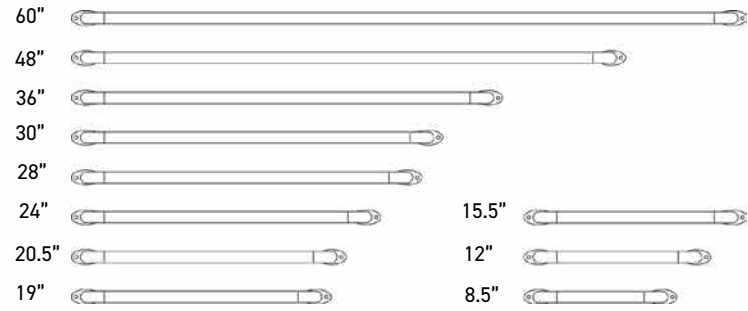

STATIONARY EXPANDABLE STEPS

FEATURES

All non-corrosive stainless steel construction

- Three ergonomic handle points
- Expandable to any custom width
- Standard white or red safety reflectors
- Option for LED lighting

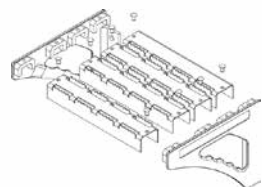

**CUSTOM FABRICATED
STAINLESS STEEL PRODUCTS**

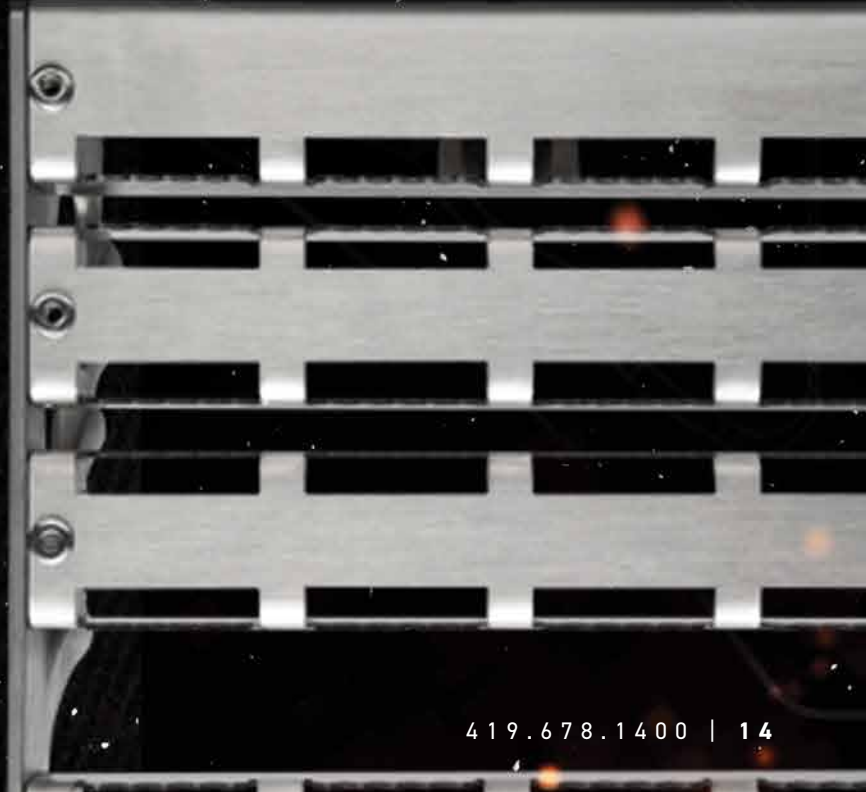

OPERATOR PANEL ASSEMBLIES AND ELECTRO MECHANICAL SUB ASSEMBLIES

FEATURES

- Interior and exterior solutions
- One-off customs to high production quantities
- Etched graphics with automotive paint fill and clear coat available on aluminum or stainless steel
- Plug and play / turnkey assemblies complete with wire harness
- Backlighting
- Vacuum forming
- Design and engineering support

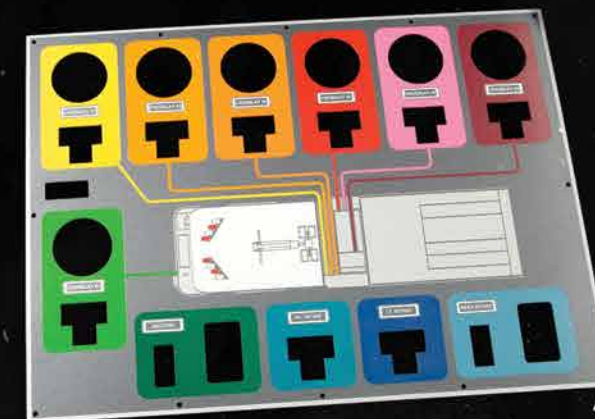

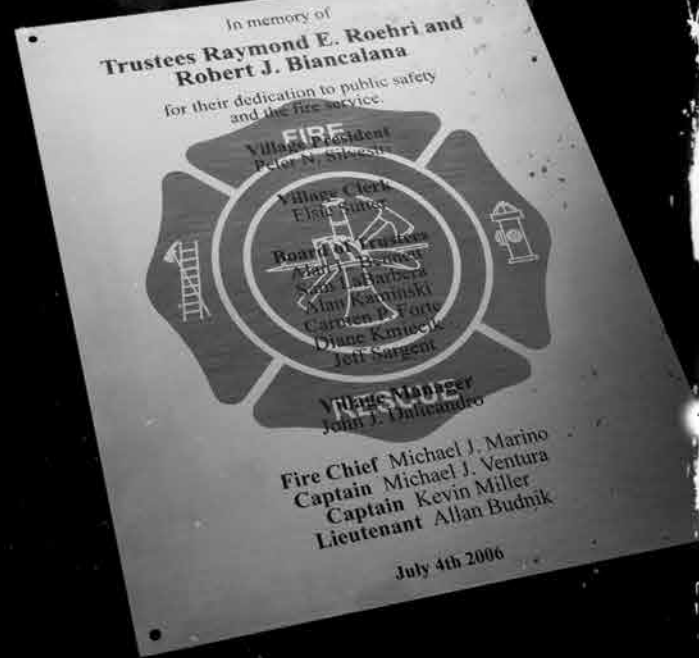

LOGOS, BRAND IDENTIFICATION, PLAQUES AND STAINLESS STEEL TAGS

LOGOS AND BADGING

MATERIALS

Non-Corrosive stainless steel

Zinc die cast

SC1 chrome plating

Etched and painted

Engineering and design support available

AWARDS AND DEDICATION PLAQUES

Design support

Customizable

Variety of materials and processes available for application

CUSTOM STAINLESS STEEL TAGS, BEZELS AND LABELS

BEZEL MATERIALS

Zinc die cast

Assorted colors

SC1 chrome plating

Standard or custom

Flex system

Consistent look and feel

TAG FEATURES

Non-Corrosive stainless steel

Customizable upon request

CAUTION, WARNING AND ATTENTION LABELS

NFPA compliant

Customizable

MATERIALS

Non-Corrosive stainless steel

Vinyl

Aluminum





VALVE CONTROLS

FEATURES

Insert area for custom labeling and color coding

Rugged over-molded santoprene handle for ergonomic feel, comfort, and superior grip

SC1 chrome plating

Large diameter pull rod

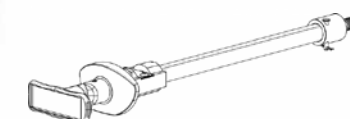

4

WORK WITH US

With over 15 years of industry experience, Signature 4 has become an established supplier for fire apparatus manufacturers.

We do it all - from standard product, to a custom solution, or something in between, our team constantly evolves and adapts to meet your desired function and look.

Contact our customer service team at 419.678.1400 or info@signature4.com about

- Catalog-featuring products
- Standard product pricing inquiries
- Custom product solutions
- Capability inquiries
- Electronic assemblies
- Engineering services
- Design and branding support
- Customized manufacturing

SINGLE (1) CYLINDER

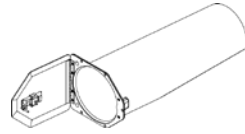

PART #	LENGTH	ANGLE	HINGE LOCATION	LATCH	1ST ACCESSORY	2ND ACCESSORY	DOOR FINISH
101252-10	25"	0		Black, Sealed			Brushed
101252-11	25"	0		Black, Flush		Latch Gasket	Brushed
101252-14	26.5"	0		Black, Sealed			Brushed
101252-15	26.5"	0		Chrome		Latch Gasket	Brushed
101252-18	25"	0		Chrome		Latch Gasket	Brushed
101252-21	25"	5	RH	Black, Flush		Latch Gasket	Brushed
101252-22	25"	5	LH	Black, Flush		Latch Gasket	Brushed
101252-23	25"	5	RH	Black, Sealed			Brushed
101252-24	26.5"	0		Black, Flush		Latch Gasket	Brushed
101252-25	23"	0		Black, Flush		Latch Gasket	Brushed
101252-26	26.5"	5	RH	Black, Flush		Latch Gasket	Brushed
101252-27	26.5"	5	LH	Black, Flush		Latch Gasket	Brushed
101252-28	25"	5	LH	Chrome	Door Gasket	Latch Gasket	Brushed
101252-29	25"	5	RH	Chrome	Door Gasket	Latch Gasket	Brushed
101252-30	26.5"	5	LH	Black, Sealed	Door Gasket		Brushed
101252-31	26.5"	5	RH	Black, Sealed	Door Gasket		Brushed
101252-35	25"	0		Black, Sealed	Door Gasket		Brushed
101252-38	25"	5	LH	Chrome		Latch Gasket	Brushed
101252-39	25"	5	RH	Chrome		Latch Gasket	Brushed
101252-40	25"	0		Black, Sealed	Door Gasket	Latch Gasket	Brushed
101252-41	25"	0		Black, Flush	Door Gasket	Latch Gasket	Brushed
101252-44	26.5"	0		Black, Flush	Door Gasket	Latch Gasket	Brushed
101252-45	23"	0		Black, Flush	Door Gasket	Latch Gasket	Brushed
101252-46	26.5"	0		Black, Sealed	Door Gasket		Brushed
101252-49	26.5"	0		Chrome	Door Gasket	Latch Gasket	Brushed
101252-50	26.5"	0		Chrome	Door Gasket	Latch Gasket	Polished
101252-53	25"	5	LH	Black, Flush	Door Gasket		Brushed
101252-54	25"	5	RH	Black, Flush	Door Gasket	Latch Gasket	Brushed
101252-56	25"	0		Chrome	Door Gasket	Latch Gasket	Brushed
101252-58	25"	5	RH	Black, Flush		Latch Gasket	Polished
101252-63	26.5"	0	RH	Black, Sealed	Door Gasket	Latch Gasket	Brushed
101252-66	23"	0		Chrome	Door Gasket	Latch Gasket	Brushed
101252-77	24.5"	0		Black, Flush	Door Gasket	Latch Gasket	Brushed
101252-78	25"	0		Black, Flush	Door Gasket	Latch Gasket	Polished

* If Hinge Location is Not Noted, Product can be Mounted Either LH or RH

DOUBLE (2) CYLINDER - WIDE DROP DOWN DOOR

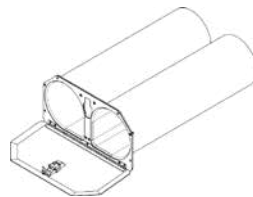

PART #	LENGTH	ANGLE	HINGE LOCATION	LATCH	1ST ACCESSORY	2ND ACCESSORY	DOOR FINISH
102069	26"	0	Bottom	Black, Flush			Brushed
102069-10	26"	0	Bottom	Black, Flush	Door Gasket		Brushed
102069-11	26"	0	Bottom	Chrome	Door Gasket	Latch Gasket	Brushed

SINGLE DOOR SINGLE (1) CYLINDER & FUEL DOOR

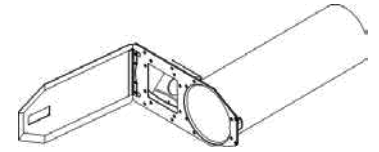

PART #	LENGTH	ANGLE	HINGE LOC.	LATCH	1ST ACCESSORY	2ND ACCESSORY	HOUSING	DOOR FINISH
101846-10	25"	0	RH	Black, Sealed			HDPE	Brushed
101846-11	25"	0	LH	Black, Sealed			HDPE	Brushed
101846-12	25"	0	RH	Black, Sealed	Door Gasket	Latch Gasket	HDPE	Brushed
101846-13	25"	0	LH	Black, Sealed	Door Gasket	Latch Gasket	HDPE	Brushed
101846-14	25"	0	RH	Black, Sealed	Door Gasket	Latch Gasket	SS	Brushed

SINGLE DOOR DOUBLE (2) CYLINDER - WIDE DOOR

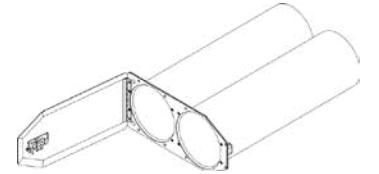

PART #	LENGTH	ANGLE	HINGE LOCATION	LATCH	1ST ACCESSORY	2ND ACCESSORY	DOOR FINISH
101400-10	25"	0		Black, Sealed			Brushed
101400-11	25"	0		Black, Flush			Brushed
101400-12	25"	0		Chrome			Brushed
101400-13	26.5"	0		Black, Sealed			Brushed
101400-14	26.5"	0		Black, Flush		Latch Gasket	Brushed
101400-15	26.5"	0		Chrome		Latch Gasket	Brushed
101400-18	25"	0		Chrome	Door Gasket	Latch Gasket	Brushed
101400-21	25"	0		Black, Sealed	Door Gasket		Brushed
101400-24	25"	0		Black, Flush	Door Gasket	Latch Gasket	Brushed
101400-25	25"	0		Black, Sealed	Door Gasket		Brushed
101400-26	26.5"	0		Black, Sealed	Door Gasket		Brushed
101400-27	26.5"	0		Black, Flush	Door Gasket	Latch Gasket	Brushed
101400-28	26.5"	0		Chrome	Door Gasket	Latch Gasket	Brushed
101400-34	26.5"	0		Black, Sealed	Door Gasket	Latch Gasket	Brushed

* If Hinge Location is Not Noted, Product can be Mounted Either LH or RH

DOUBLE (2) CYLINDER - CUSTOM

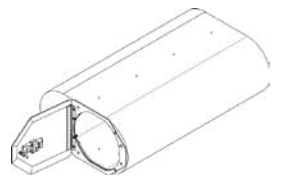

PART #	LENGTH	ANGLE	HINGE LOCATION	LATCH	1ST ACCESSORY	2ND ACCESSORY	DOOR FINISH
101895-10	26.5"	0		Chrome	Door Gasket	Latch Gasket	Brushed
101895-11	26.5"	0		Chrome	Door Gasket	Latch Gasket	Polished
101895-13	25"	0		Chrome	Door Gasket	Latch Gasket	Polished

SINGLE DOOR TRIPLE (3) CYLINDER - WIDE DOOR

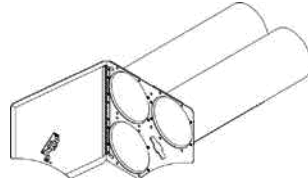

PROJECT #	LENGTH	ANGLE	HINGE LOCATION	LATCH	1ST ACCESSORY	2ND ACCESSORY	DOOR FINISH
101411-10	25"	0	LH	Black, Sealed			Brushed
101411-11	25"	0	RH	Black, Sealed			Brushed
101411-12	25"	0	LH	Black, Flush			Brushed
101411-13	25"	0	RH	Black, Flush			Brushed
101411-14	25"	0	LH	Chrome			Brushed
101411-15	25"	0	RH	Chrome			Brushed
101411-22	23"	0	LH	Black, Sealed			Brushed
101411-23	23"	0	RH	Black, Sealed			Brushed
101411-27	25"	0	RH			Latch Gasket	

FUEL DOORS

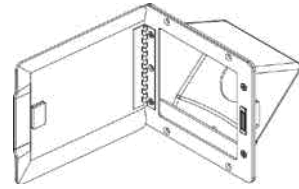

PART #	ENCLOSURE	HINGE LOCATION	LATCH	1ST ACCESSORY	DOOR FINISH
101426	HDPE	LH	Magnetic		Brushed
101426-10	HDPE	LH	Magnetic	Gasket + Drain Elbow	Brushed
101426-11	HDPE	LH	Magnetic	Gasket	Brushed
101426-13	HDPE	LH	Magnetic	SS Fuel Pipe + Gasket	Brushed
101426-14	SS	LH	Magnetic	Gasket	Brushed
101426-15	HDPE	LH	Magnetic	Gasket	Polished
101426-17	HDPE	RH	Magnetic	Gasket	Brushed
101426-22	HDPE	LH	Magnetic	Drain Elbow + Gasket + Fill Pipe	Brushed
101426-23	HDPE	LH	Magnetic	Filler Neck + Diesel Cap	Brushed
101426-24	HDPE	LH	Magnetic	Filler Neck	Brushed
101426-25	HDPE	LH	Magnetic	Drain Elbow + Gasket + Filler Pipe + Diesel Cap	Brushed
102101	HDPE	LH	Push Button	Gasket + Drain Elbow	Brushed
102101-11	HDPE	RH	Push Button	Gasket	Brushed
102101-12	HDPE	LH	Push Button	Gasket	Brushed
102101-10	SS	LH	Push Button	Gasket + Drain Elbow	Brushed

FOLDING STEPS

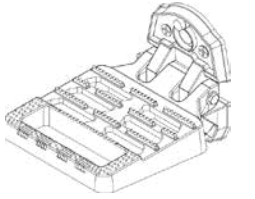

PART #	DESCRIPTION	NFPA	FINISH
101953-1	Folding Step + Top White LED Light Only	YES	Chrome Plated
101953-2	Folding Step + Dual Top and Bottom White LED Lights	YES	Chrome Plated
101953-3	Folding Step Without Lights	YES	Chrome Plated

VALVE CONTROLS



PART #	DESCRIPTION	STROKE LENGTH	SWIVEL END TYPE	FINISH
101972-22	Push Pull, Smooth Bezel	9.75"	1/2" x 20 Female Thread	Chrome Plated
101972-46	Push Pull, Smooth Bezel	9.75"	1/2" x 20 Male Thread	Chrome Plated



SIGNATURE 4
149 HARVEST DRIVE
COLDWATER, OH 45828
SIGNATURE4.COM

FOR STANDARD AND CUSTOM PRODUCT INQUIRIES
EMAIL US AT INFO@SIGNATURE4.COM
OR CALL 419.678.1400